

HST WITH A 24 VAC THERMOSTAT CONVERTED TO A UC1

FACTORY WIRING

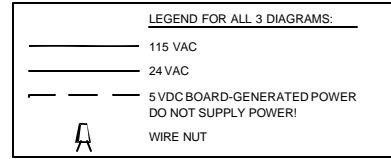

OLD STYLE 24/115 TIMER RELAY

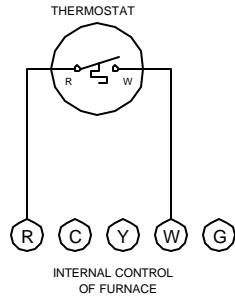
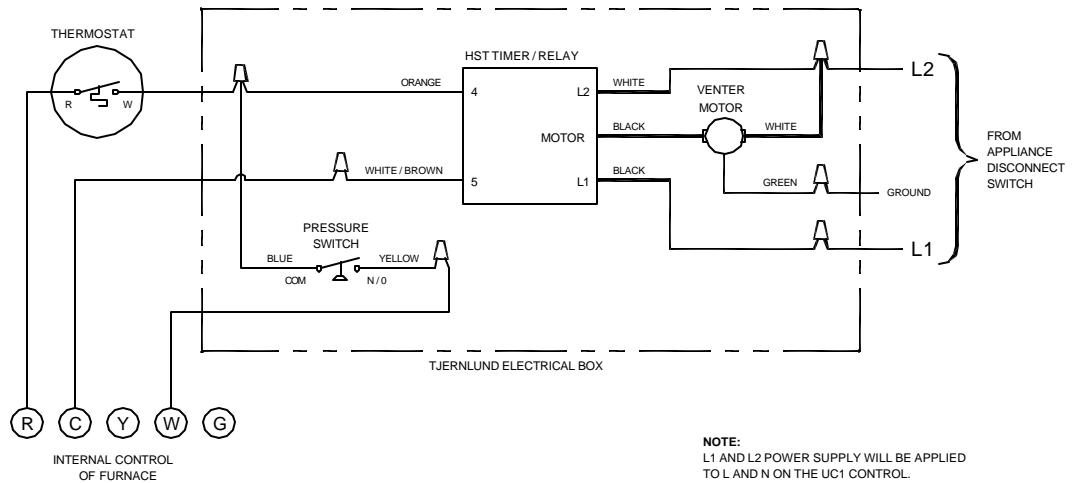

NEW STYLE UC1 CONTROL

